

UPDATED ON

July 2024

MISSING NO.

TECHNICAL RIDER

ENGLISH



Overview & Members

THIS TECHNICAL RIDER IS A DEFAULT CONFIGURATION. WE ARE HAPPY TO DISCUSS THE DETAILS AND ADAPT TO THE CONSTRAINTS OF THE VENUE, IF REQUIRED.

MISSING NO. is a metalcore band with a defined sound aesthetic. The band relies on digital amps, samples with backing tracks, and a custom IEM setup to perform a show.

Our sonic influences gravitate towards **modern, heavy metalcore tones** such as Bring Me The Horizon, Wage Ware, and Parkway Drive. Low, punchy and resonant kicks and snares, gritty bass, smooth guitar, and a large focus on vocals with a Lead vocalist reinforced by the additional vocals of the instrumentalists. This sound is heavily supported by synth and choirs, brought on stage via backing tracks.

For references of our current sound, you can listen to our latest single : MAYBE.

<https://youtu.be/61qLltBRROc>

Shows last between 25 and 30 minutes, and only include original songs. A setlist with timecodes, tempo and additional info can be provided if requested.

MISSING NO. is :



MARTIAL
Lead Vocals



ALEXIS
Bass & Vocals



VALENTIN
Guitar, Vocals
& Technical



REMY
Drums, Vocals
& Technical

Stage Layout

MISSING NO. requires a stage of **5m x 5m** to accommodate the following stage layout. If the required space cannot be provided, please contact us to discuss the best solution for the stage layout.

The **monitoring wedges must be turned off** during MISSING NO. performance, as the band uses and manages its own In Ear Monitoring system autonomously. The system is pre-balanced to facilitate the setup at the venue.

The **IEM Rack & Computer that handles all the IEM mixing and backing tracks** can be placed in close proximity to the venue's stage box, but **must be easily accessible by the drummer** during the show to handle the playback.

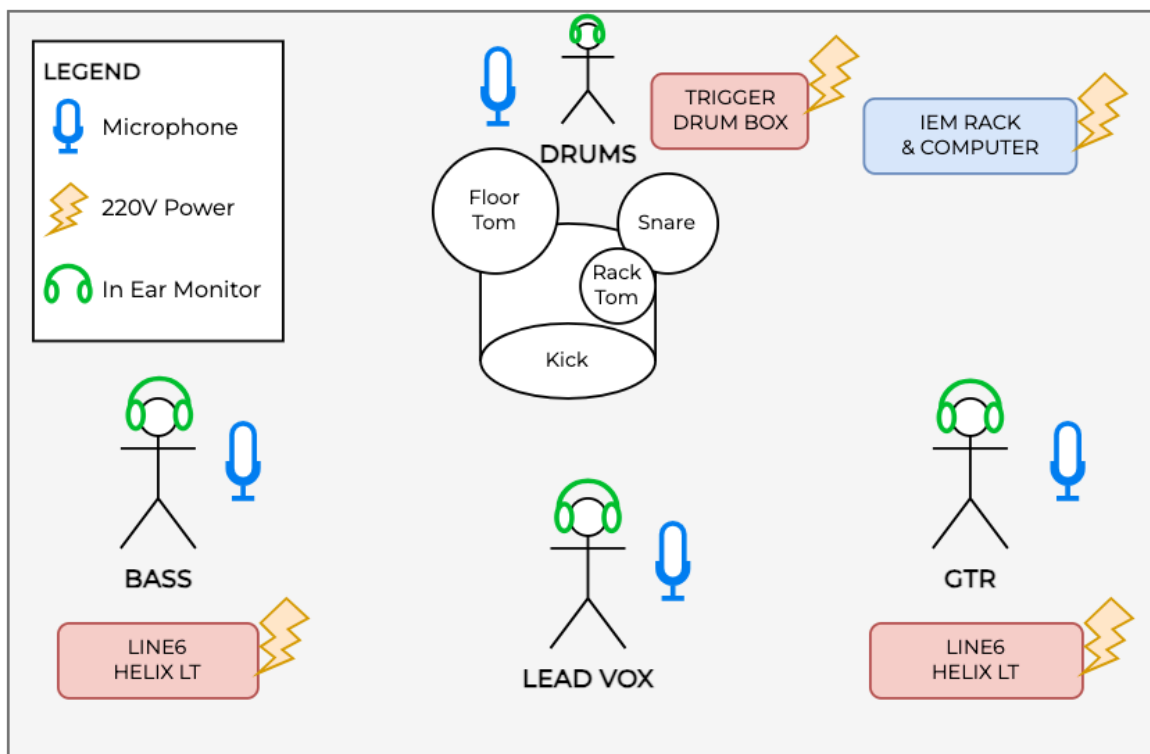

Channel configuration

Note:

- Track numbers are informational and left to the discretion of the FOH mixing engineer.
- "Split" indicates that the source is splitted in the IEM rack at MIC-level before being sent to the FOH mixer. This is described in the **Detailed Considerations: IEM Setup** section.

#	Source	Split	Mic / Source	Comments
01	LEAD VOCAL	YES	SM58	
02	BASS AMP MONO		HELIX LT	XLR, LINE level
03	BASS VOCAL	YES	SM58	
04	GUITAR AMP L		HELIX LT	XLR, LINE level
05	GUITAR AMP R		HELIX LT	XLR, LINE level
06	GUITAR VOCAL	YES	SM58	
07	TRIG KICK L		Roland TM-2	TRS, LINE level
08	TRIG KICK R		Roland TM-2	TRS, LINE level
09	KICK FRONT/IN		Beta 52 / Beta 91A	Preferred IN
10	SNARE TOP	YES	SM57	
11	SNARE BOTTOM		SM57	Mic is optional
12	RACK TOM 1		e604	
13	RACK TOM 2		e604	2nd rack tom is optional
14	FLOOR TOM		e604 / Beta 52	
15	OVERHEAD L	YES	Lewitt LCT 140	
16	OVERHEAD R	YES	Lewitt LCT 140	
17	DRUMS VOCAL	YES	SM58	
18	TRACK L		COMPUTER	XLR, LINE level
19	TRACK R		COMPUTER	XLR, LINE level

Detailed considerations

FOH Mixing : Even though it manages its own IEM mixer, the band requires a FOH mixer and mixing engineer for a show.

Drums : The band can either bring its own drum kit, or share a drum kit with the other artists for the show. In such a case, the band requires at least a floor and rack tom, with a preferred second rack tom if possible.

The band will bring its own cymbals, snare, and kick pedal, and does not share these items with the other artists. The Kick trigger requires stereo as it generates a lot of stereo reverb.

Lights : The band currently does not have programmed lights, but can provide a detailed rider if possible / necessary, with colors, tempos, transitions, and eventual events during the show.

IEM Setup : The band uses a custom IEM Rack setup to control their monitors, as well as the backing tracks for the show. This rack requires a list of inputs described in the **Channel Configuration** section. Stage mics are splitted using an Art S8 mic-level splitter. The Direct Output is provided to the venue, and the Isolated Output is kept for monitoring. Both Line6 HELIX LT and the TM-2 trigger module are outputting directly from the XLR outputs and are not splitted using the Art S8. The following diagram details the wiring of the IEM Rack and its connections with the FOH mixer.

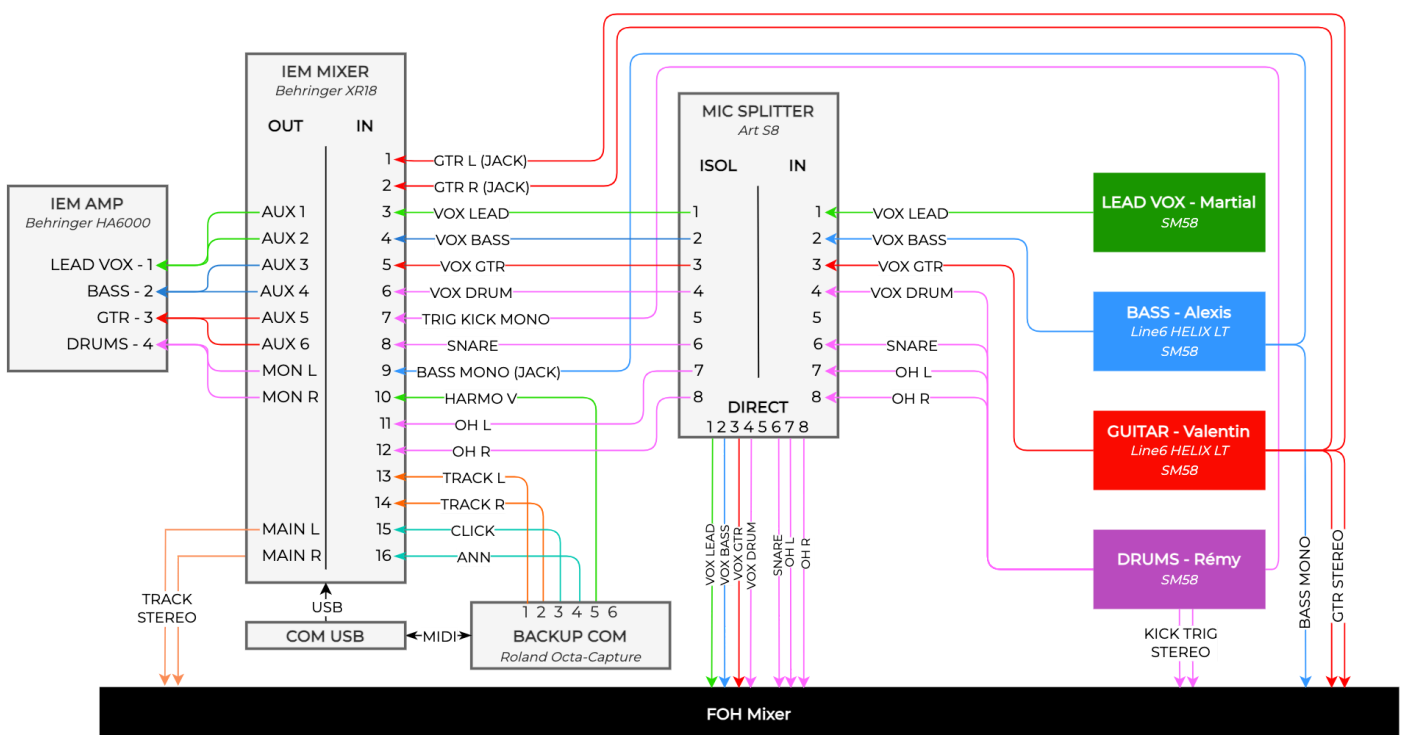

Hospitality

Catering : MISSING NO. does not require catering, however some snacks would be greatly appreciated. Note that some band members have allergies to various foods. Please get in touch with us if you plan to provide catering so we can detail and plan a list of options.

Water bottles around the stage during the show are greatly appreciated.

Changing Room : MISSING NO. requires a private changing room with a mirror, and a sink with hot water in order to prepare for the show.

Contact

For any technical, booking or organization inquiries, feel free to contact us via mail, Instagram, or by phone using the number we'll provide when initiating contact.

We are available to discuss adaptations to any changing conditions. This is a base document, but we can set up other technical solutions if need be.

Thank you for your consideration, we are happy to collaborate with you to make this show a great moment for everyone involved !

